

SPECIFICATIONS

MODEL	CK2610	CK2610 HST	CK3510	CK3510 HST	CK4010	CK4010 HST	
ENGINE							
Model	3A165LWM-U	3A165LWH-U	3H-TM4A	3H-TH4A	3H-TM4A	3H-TH4A	
Type	3 Cyl., In-line Vertical, Water-cooled 4-cycle Diesel		3 Cyl., In-line Vertical, Water-cooled 4-cycle Diesel, CRDI				
Engine Gross	hp (kW)	24.5 (18.2)	34.9 (26)		39.6 (29.5)		
PTO @ 540 rpm	hp (kW)	21.7 (16.2) 21.5 (16)	31.8 (23.7)	30.8 (22.9)	34.8 (25.9)	33.3 (24.8)	
Displacement	cu. in. (cc)	100.5 (1,647)		111.4 (1,826)			
Rated Revolution	rpm	2,600					
Fuel Tank Capacity	US gal. (ℓ)	9 (34)					
DRIVE TRAIN							
Clutch	Dry dual stage	Dry single stage	Dry dual stage	Dry single stage	Dry dual stage	Dry single stage	
Transmission	Manual	HST	Manual	HST	Manual	HST	
Speeds	9×3	Infinite	9×3	Infinite	9×3	Infinite	
Differential Lock	Rear Standard						
Brake	Wet Multi Disc						
PTO Type	Live						
Rear PTO (Standard)	rpm	540					
Mid PTO (Optional)	rpm	(2,000)					
4WD Type	Mechanical						
HYDRAULIC SYSTEM							
Pump	Gear						
Pump Capacity (Max. Flow Rate)	gpm (L/min)	11.7 (44.4)					
3-Point Hitch	Category I						
Maximum Lifting Capacity (24" aft. of hitch)	lb. (kg)	1,631 (740)					
Hydraulic Lift Control System	Position						
Number of Remote Valves	(4 Optional)						
Steering	Hydrostatic Power Steering						
TIRE SIZE							
Front AG. (Turf, Industrial)	7-16 (28×8.5-15/6, 27×8.5-15)						
Rear AG. (Turf, Industrial)	11.2-24 (41×14-20/4, 15-19.5)						
TRAVELING SPEEDS							
Forward	mph (km/h)	0.77~10.08 (1.24~16.23)	0~10.31 (0~16.60)	0.94~14.62 (1.52~23.53)	0~14.85 (0~23.91)	0.94~14.62 (1.52~23.53)	0~14.85 (0~23.91)
Reverse	mph (km/h)	0.96~6.58 (1.55~10.60)	0~9.25 (0~14.94)	1.18~9.55 (1.90~15.38)	0~13.37 (0~21.52)	1.18~9.55 (1.90~15.38)	0~13.37 (0~21.52)
DIMENSIONS							
Overall Length (Includes 3-pt Hitch)	in. (mm)	120.9 (3,070)					
Overall Width (Minimum Tread)	in. (mm)	54.5 (1,385)					
Overall Height (From Top of ROPS)	in. (mm)	99.2 (2,520)					
Wheelbase	in. (mm)	65.7 (1,670)					
Min. Ground Clearance	in. (mm)	13.4 (340)					
Tread	Front (AG.)	in. (mm)	48.2 (1,225)				
	Rear (AG.)	in. (mm)	47.6 (1,210)				
Min. Turning Radius (With Brake)	ft. (m)	8 (2.4)					
Weight with AG. Tires	lb. (kg)	2,646 (1,200)	2,701 (1,225)	2,679 (1,215)	2,734 (1,240)	2,679 (1,215)	2,734 (1,240)

* NOTE : Specifications and design are subject to change without notice.



KIOTI Tractor Division
 DAEDONG - USA, INC.
 6300 KIOTI Drive, Wendell, NC 27591 USA
Toll free 877-60-KIOTI • Fax 919-374-5001
Web www.KIOTI.com

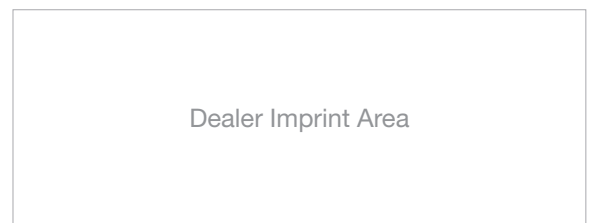

Dealer Imprint Area



STANDARD EQUIPMENT

- Parking Brake
- Illuminated Dashboard
- Head Lamp
- Signal Lamp
- Flip Up PTO Cover
- Cup Holder
- Single Lever Joystick

OPTIONAL EQUIPMENT

- Field Option Cabin
- Mid PTO Kit
- Rear Working Light Kit
- Cruise Control (HST only)
- Link Pedal (HST only)
- Dual Remote Valves (2 Spring Valves)
- Dual Remote Valves (2 Detent Valves)
- Dual Remote Valves (1 Detent Valve & 1 Spring Valve)
- Sunshade
- Clevis Type Drawbar
- Tool Box
- Side View Mirror
- Telescopic Lower Link
- Fuel Heater Kit (CK3510, CK3510 HST, CK4010, CK4010 HST only)
- Dual Air Cleaner Element
- Deck Mat
- RH Leveling Box
- Armrest
- Horn

ATTACHMENTS

- Front End Loader
- Backhoe
- Snowblower
- Contact your local KIOTI dealer for available implements and attachments.



Front End Loader

The KIOTI KL4030 front end loader is specifically designed for the CK10 Series model tractors, providing efficient performance with single lever joystick control. The KIOTI loader, with a built-in parking stand, is designed to be quickly and easily attached and detached. KL Series loaders utilize the tractor's hydraulic system, feature single-lever control with float and come with a bucket level indicator.

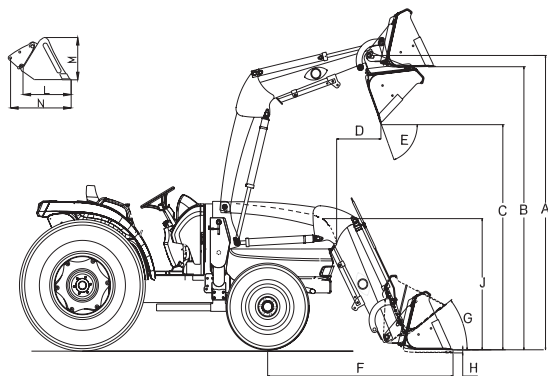

Loader Specifications

MODEL	KL4030
A Maximum Lift Height to Pivot Pin	98.4 in. (2,500 mm)
B Clearance w/ Bucket Level	93 in. (2,360 mm)
C Clearance w/ Bucket Dumped (45°)	79.1 in. (2,010 mm)
D Reach at Maximum Height	27.2 in. (690 mm)
E Maximum Dump Angle	48°
F Reach w/ Bucket on Ground	62.2 in. (1,580 mm)
G Maximum Rollback Angle	28°
H Digging Depth Below Grade	5.3 in. (135 mm)
J Overall Height in Carry Position	49.6 in. (1,260 mm)
L Bucket Depth (Inner Shell)	19.9 in. (505 mm)
M Bucket Height	20.7 in. (526 mm)
N Bucket Length (Pivot Pin)	26.9 in. (682 mm)
Lift Capacity at 59.84 in. (1,520 mm) Pivot Pin Height	1,835 lbs. (832 kg)
Breakout Force at Pivot Pins	3,464 lbs. (1,571 kg)
Relief Valve Setting (Loader Control Valve)	2,560 psi
Rated Flow (Tractor System)	6.9 gpm (26.12 L/min)
Bucket Sizes Available (QA)	60 in. / 66 in.
Approximate Weight (With Bucket)	60 in.: 959 lbs. (435 kg) / 66 in.: 981 lbs. (445 kg)
Bucket Capacity (Heaped)	60 in.: 9.39 cu. ft. / 66 in.: 10.10 cu. ft.
Bucket Rollback Force at Ground Line	1,763.7 lbs. (800 kg)
Cycle Times	2,600 rpm (Full)
Raise Boom Frame	3.9 sec
Lower Boom Frame	2.3 sec
Dump Bucket	3.2 sec
Retract Bucket	1.9 sec

* Specifications and design are subject to change without notice.

* Based on field inventory, previous loader models (KL2610 and KL4010) may still be available through a local dealer. Specifications available at KIOTI.com.

Backhoe

The KIOTI KB2475L backhoe lets you trench up to 89.7" deep with a bucket dig force up to 2,817 pounds. The KB2475L Backhoe features subframe mounting, responsive two-lever controls with exceptional feathering, hydraulic stabilizers, transport lock and a variety of standard and heavy-duty buckets.

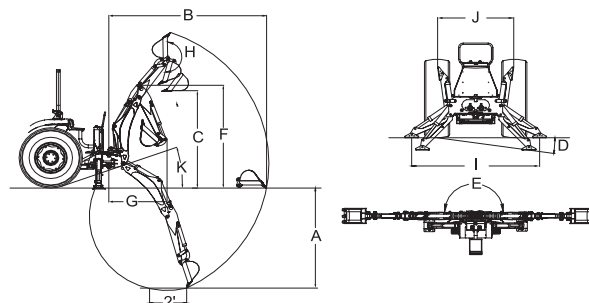

Backhoe Specifications

MODEL	KB2475L
A Digging Depth (Two Foot Flat Bottom)	89.7 in. (2,280 mm)
B Reach from Center Line of Swing Pivot	125.1 in. (3,180 mm)
C Loading Height (Bucket at 60°)	72.4 in. (1,840 mm)
D Maximum Leveling Angle	10°
E Swing Arc	180°
F Transport Height (Maximum)	83.5 in. (2,120 mm)
G Transport Overhang	49 in. (1,245 mm)
H Bucket Rotation	180°
I Stabilizer Spread (Down Position)	68.7 in. (1,745 mm)
J Stabilizer Spread (Up Position)	46.4 in. (1,180 mm)
K Angle of Departure	21°
Shipping Weight (Without Bucket)	880 lbs. (399 kg)
Bucket Digging Force	2,817 lbs. (1,278 kg)
Dipperstick Digging Force	2,105 lbs. (955 kg)
Operating Pressure	2,466 psi (170 bar)

Cylinders

Cylinder	Bore DIA	Retracted Length	Stroke	Rod DIA
Boom	2.36	20.66	12.36	1.37
Bucket	2.36	18.70	9.64	1.37
Dipperstick	2.36	19.68	11.20	1.37
Swing	2.36	15.23	7.87	1.37
Stabilizer	1.96	18.30	10.43	1.18

Buckets

Bucket	Teeth Quantity	Struck Capacity	Heaped Capacity	Shipping Weight
9" Bucket	3	0.73 cu. ft.	0.87 cu. ft.	46 lbs.
12" Bucket	3	1.01 cu. ft.	1.24 cu. ft.	56 lbs.
16" Bucket	3	1.38 cu. ft.	1.76 cu. ft.	64 lbs.
18" Bucket	4	1.56 cu. ft.	2.02 cu. ft.	70 lbs.
24" Bucket	5	2.11 cu. ft.	2.82 cu. ft.	94 lbs.
36" Bucket	6	2.78 cu. ft.	4.00 cu. ft.	114 lbs.

* Specifications and design are subject to change without notice.



CK10 Series

25 - 40 HP



CK10 SERIES

TOUGH JOBS NEED A TOUGHER TRACTOR.

Looking for a durable compact tractor?
Look no further than a CK10.
With the HP options you want and the power,
performance and comfort you need,
sounds like it's time for a test drive.

Manual or HST

Eco-Friendly Diesel Engine

Great Value

Open Station Platform

High Ground Clearance

Single Lever Joystick





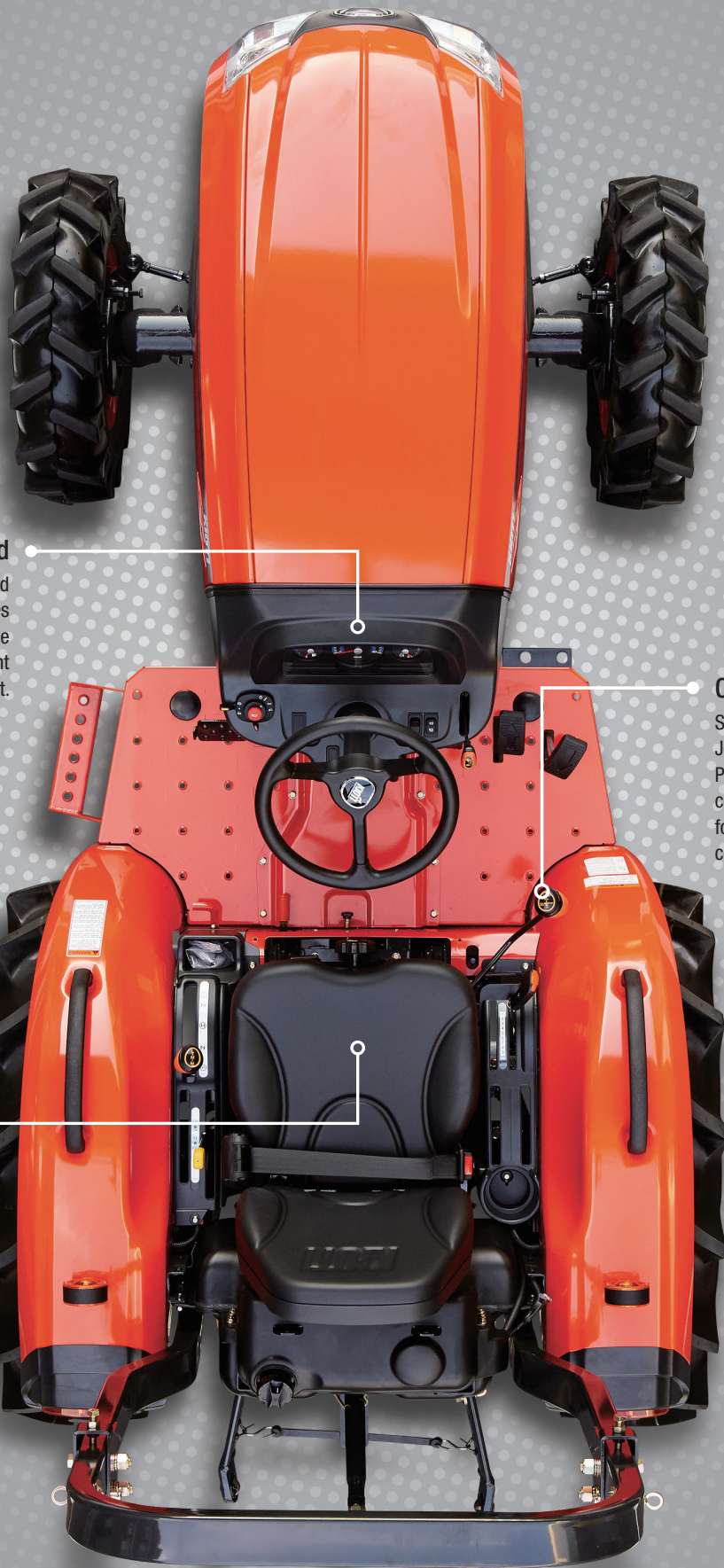

Illuminated Dashboard

The illuminated dashboard ensures great visibility while working in bright daylight or at night.

Controls

Standard Single Lever Joystick and Dual HST Pedals (HST models) are conveniently located for optimum operator comfort.

Comfortable Seat

With a high quality seat the operator enjoys a comfortable and smooth ride. Equipped with a seat belt and operator presence switch, operator safety is a focus.

EXPERIENCE THE POWERFUL CK10



3-Point Control Lever

The ergonomic 3-point control lever has smooth motion for reduced effort and improved control.



4WD

4WD comes standard on all models and is engaged with a simple push/pull lever.



Power Steering

The standard power steering minimizes the effort required to make tight, repetitive turns.



Tail Lamp & Flasher

The stylish tail lights improve operator safety by increasing visibility when the lights are on. When traveling on the road, the mounted flasher alerts oncoming traffic to your presence.



Single Lever Joystick

Front end loader work is made easier by the use of a single lever joystick. The lever returns to neutral when released. A float position allows the bucket free flotation over the ground surface.



Rear Differential Lock

The differential lock lever allows for easy engagement/disengagement of the differential allowing you to maintain traction on uneven or muddy terrain.



Eco-Friendly Diesel Engine

The eco-friendly diesel engine provides powerful performance and improves fuel efficiency while reducing noise levels. With this eco-friendly Tier 4 engine, the CK10 Series offers the operator a quiet work environment with powerful performance.

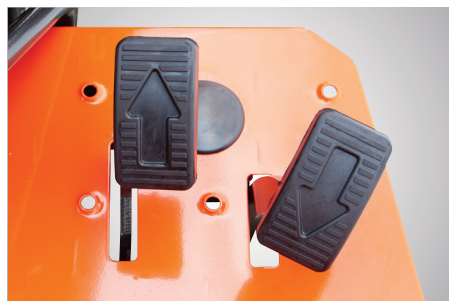

Dual HST Pedals

HST models employ a two pedal system for forward and reverse with smooth engagement, acceleration and deceleration. Pedal pressure is minimized which reduces operator fatigue during long hours of use and when doing repetitive tasks.



Powerful HST Transmission

HST models feature a performance proven, heavy-duty HST that delivers power and efficiency. The three range transmission (Hi/ Mid/ Low) with twin pedal operation makes your job easier, smoother and safer.



9x3 Manual Transmission

Manual transmission models feature 9 Forward and 3 Reverse speeds delivering heavy duty performance. Second and Reverse gears are synchronized for efficient forward and reverse operations requiring frequent shifting.



Center Marker

The center ridge marker on the hood assists with maintaining straight lines during operation.



High Ground Clearance

The minimum ground clearance of 13.4 in. provides sufficient clearance for use on rocky or uneven terrain.



KIOTI COMPACT TRACTOR