

# TRAILER-MOUNTED BOOMS



**3522 A - 3632 T**  
**4527 A - 5533 A**  
**6543 A**

## Access on the move

- Hydraulic outriggers and automatic leveling allow operation in under 30 seconds
- Superior combination of industry leading capacity and outreach
- Can be towed by a standard half-ton pickup truck - No commercial driver's license needed

## Exceptional productivity

- Air / water lines and 110V GFI protected power to the platform



### 3632T

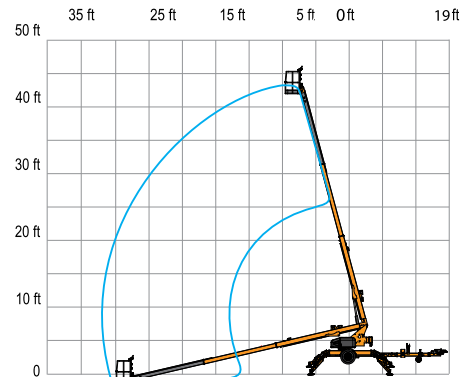

### 3522A 4527A 5533A 6543 A

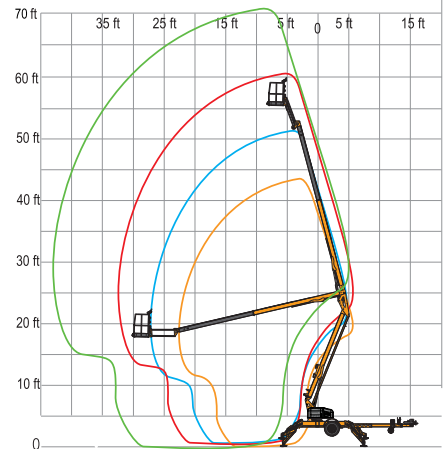

**Haulotte**   
GROUP

[www.haulotte-usa.com](http://www.haulotte-usa.com)



# 3522 A - 3632 T - 4527 A - 5533 A - 6543 A

## TRAILER-MOUNTED BOOMS

### TECHNICAL DATA

**3522 A**      **3632 T**      **4527 A**      **5533 A**      **6543 A**

Working height	41 ft 9 in	43 ft 6 in	51 ft	61 ft 3 in	71 ft
Platform height	35 ft 9 in	37 ft 6 in	45 ft	55 ft 3 in	65 ft
Horizontal outreach (from centerline)	22 ft 6 in	32 ft	27 ft	33 ft 5 in	43 ft
Horizontal outreach (from edge of footpad)	17 ft 5 in	27 ft	21 ft	27 ft 4 in	37 ft
Up and over height	19 ft	N/A	20 ft 9 in	23 ft 1 in	24 ft 2 in
Lift capacity	500 lbs				
A - Length - stowed	16 ft 3 in	22 ft 8 in	20 ft 8 in	23 ft 8 in	24 ft
B - Width stowed	5 ft 6 in			5 ft 7 in	5 ft 11 in
C - Height stowed	6 ft 8 in			6 ft 9 in	7 ft
D x E - Platform size	4 ft 1 in x 2 ft 9 in				
F - Widest Point	11 ft 10 in	13 ft 9 in	13 ft 9 in	14 ft 8 in	14 ft 8 in
G - Widest Point	12 ft 2 in	13 ft 6 in	13 ft 6 in	15 ft	15 ft
Turntable rotation	350° non-continuous				
Jib - length	4 ft 3 in	N/A		4 ft 3 in	
Jib - Vertical Motion	150° (+70 / -80)	N/A		150° (+70 / -80)	
Tow speed rating	65 mph				
Leveling capability	12.5°				
Tire size	ST 225/75 D15		ST 225/75 R15	ST 215/75R 17.5	
Power source	4 x 6 V 245 amp-hr				
Tongue weight (no options)	245 lbs	200 lbs	290 lbs	335 lbs	550 lbs
Weight (no options)	3400 lbs	4440 lbs	4200 lbs	4800 lbs	7700 lbs

### STANDARD EQUIPMENT

- Hydraulic outriggers
- Tilt alarm/sensor
- Hour meter and battery condition indicator
- Automatic leveling system and self-leveling platform
- 110V GFI protected outlet to platform
- Easy to use controls
- Air and water line to platform
- Inboard 25 amp charger
- Integrated forklift pockets
- Hydraulic surge brakes (trailer)

### OPTIONS & ACCESSORIES

- Spare tire and mounting kit
- DC / Gas hybrid
- Manual platform rotator - 120° stop point to stop point
- Flashing beacon
- Fluorescent tube caddy
- Combination hitch
- Tool tray
- Electric brakes (trailer)
- Drive and Set

