

ELECTRIC SCISSOR LIFTS

WARRANTY

HAULOTTE

5 YEARS

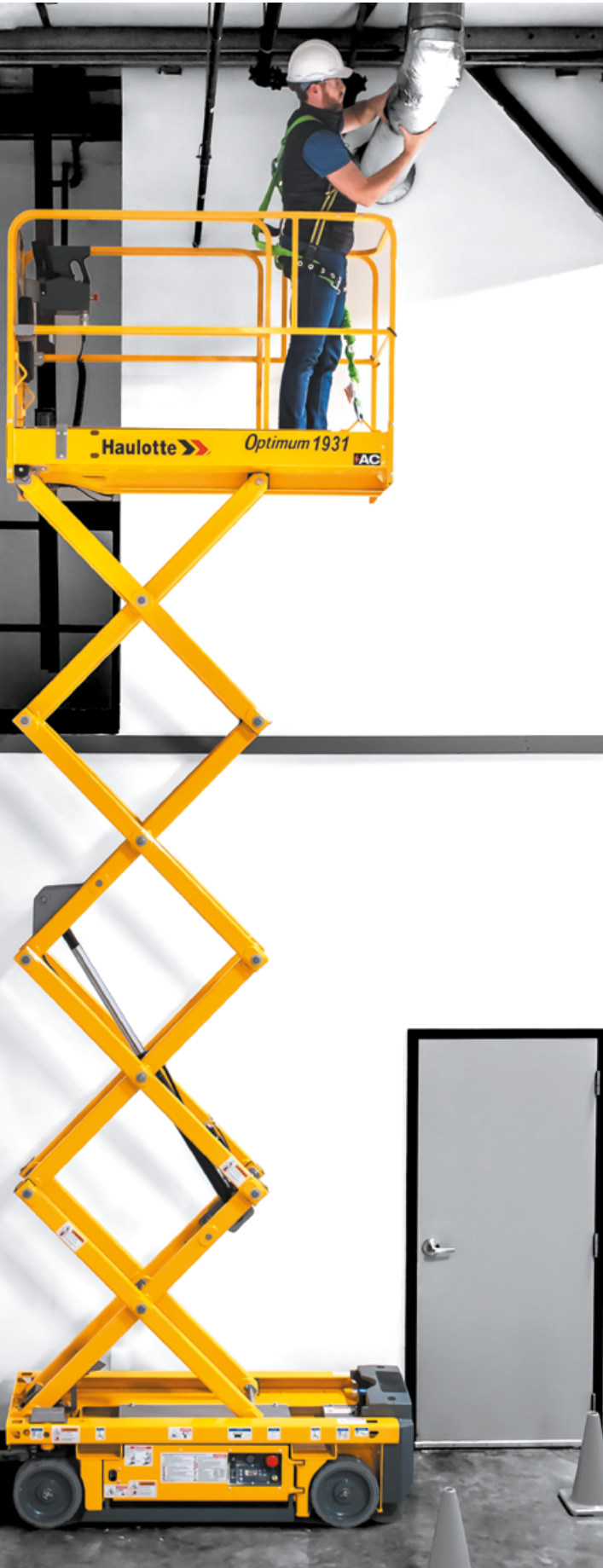

OPTIMUM 1931



BEST DRIVING AND LIFTING EXPERIENCE

- > AC powered
- > Precision driving control
- > Smooth proportional motions
- > Industry leading turning radius

ULTIMATE VERSATILITY

- > Pass through standard doorways
- > Mobile pothole protection
- > Indoor - outdoor rated

MINIMAL MAINTENANCE AND DOWNTIME

- > Maintenance free AC motors
- > Easy access swing out trays
- > Haulotte Activ'Screen (onboard diagnostics)
- > Smart transportability

LONGER LIFETIME

- > Haulotte Activ'Energy Management takes care of your batteries
- > Extreme durability
- > Optimized total cost of ownership

OPTIMUM 1931

ELECTRIC SCISSOR LIFTS

TECHNICAL DATA

OPTIMUM 1931 AC

Working height	24 ft 11 in
Platform height	18 ft 11 in
Driveable at full height up to	18 ft 11 in
Lift capacity - inside	500 lb (2 pers.)
Lift capacity - outside	500 lb (1 pers.)
Lift capacity - extension	500 lb
A Platform length - outside	5 ft 8 in
B Platform length - extended	8 ft 6 in
Extension length	2 ft 10 in
C Platform width - outside	2 ft 5 in
D Height - stowed	6 ft 6 in
F Overall width	2 ft 7 in
G Length	6 ft 3 in
H Wheelbase	4 ft 6 in
I Ground clearance	4 in
Ground clearance - pothole guards deployed	1 in
Drive speed	0.3 - 2.8 mph
Gradeability	25 %
Tilt alarm	1.5° / 3°
Turning radius - outside	4 ft 11 in
Batteries	24 V - 225 Ah (C20)
Hydraulic system capacity	1.8 gal
Weight	3,500 lb

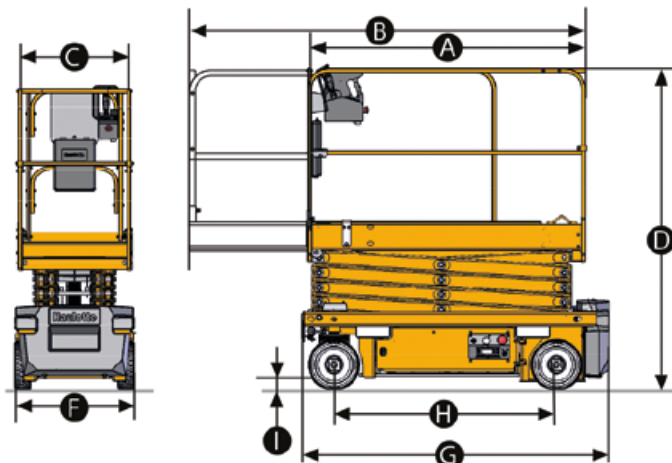

STANDARD EQUIPMENT

- > Haulotte Activ'Energy Management: Smart CAN charger
- > 24 V electric drive brushless AC motors
- > Battery level indicator on upper and lower control boxes
- > Haulotte Activ'Screen (battery charge, Hourmeter, service alert & failures icons in code or in full text...)
- > Pothole guards
- > 2 swing out trays
- > Lateral fork lifting pockets, lifting and tie down points
- > 2 front steering and 2 rear driving wheels
- > Proportional controls
- > Electrical or manual brake release system
- > Tilt sensor
- > AC power to the platform
- > Non-marking tires

OPTIONS AND ACCESSORIES

- > Haulotte Activ'Energy Management: automatic or manual batteries waterfilling system
- > Folding guardrails
- > AC Power to the platform (standard on US machines)
- > Cold weather hydraulic oil
- > Telematics ready
- > Flashing beacon
- > Dual flashing beacons
- > Work light
- > Panel carrier
- > Pipe cradle

